

A manual to the skeletal measurements of  
the seal genera *Halichoerus* and *Phoca*  
(Mammalia: Pinnipedia)

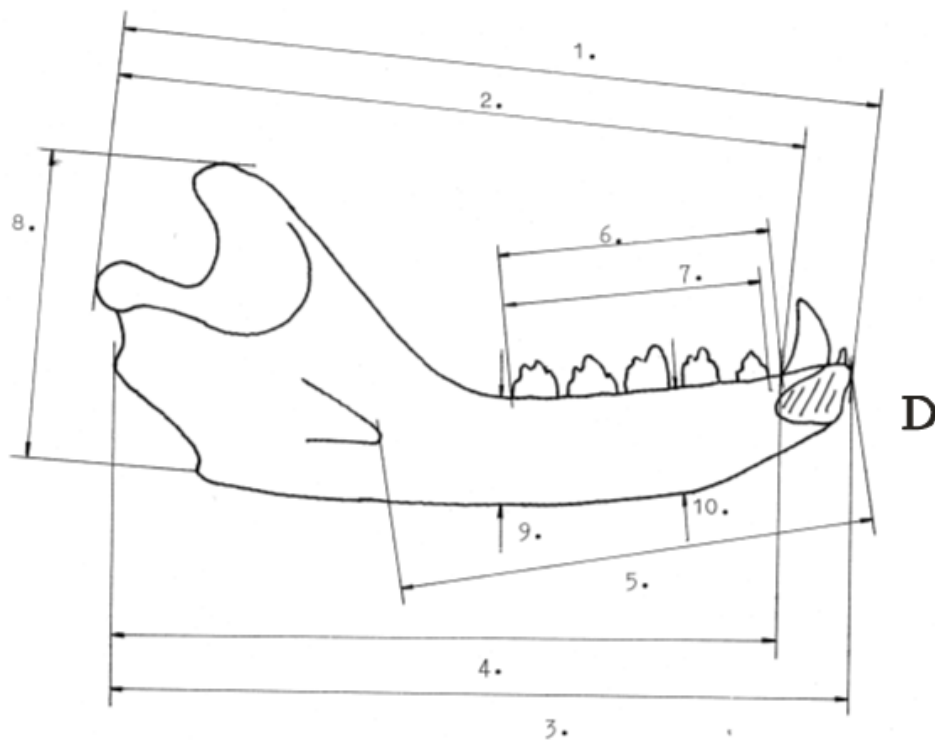

Per G.P. Ericson and Jan Storå



Naturhistoriska  
riksmuseet

Cover: How to measure a phocid mandible (illustration taken from the manual).

Publisher: Swedish Museum of Natural History  
Publishing city: Stockholm  
Publication date: 2020-11-19  
Version: 1.1  
ISSN: 0585-3249  
© Swedish Museum of Natural History, Stockholm

Swedish Museum of Natural History  
Box 50007  
SE-104 05 Stockholm  
Sweden  
[www.nrm.se](http://www.nrm.se)

This report can be downloaded as a pdf-document from the website of the Swedish Museum of Natural History.

Please cite:

Ericson, P.G.P. & Storå, J. 2020. A manual to the skeletal measurements of the seal genera *Halichoerus* and *Phoca* (Mammalia: Pinnipedia). *Reports from the Swedish Museum of Natural History*. 2020:4. *Naturhistoriska riksmuseets småskriftserie*.

Note that this publication replaces an identical version distributed since 1999 as a stencil from the Department of Vertebrate Zoology, Swedish Museum of Natural History.

# **A manual to the skeletal measurements of the seal genera *Halichoerus* and *Phoca* (Mammalia: Pinnipedia)**

Per G. P. Ericson <sup>1</sup>, Jan Stora <sup>2</sup>

<sup>1</sup>Department of Bioinformatics and Genetics, Swedish Museum of Natural History, P.O. Box 50007, SE-10405 Stockholm, Sweden (per.ericson@nrm.se)

<sup>2</sup>Osteoarchaeological Research Laboratory, Department of Archaeology and Classical Studies, Stockholm University, SE-10691 Stockholm, Sweden (jan.stora@ofl.su.se)

## **Introduction**

This manual has been compiled to facilitate osteometric studies of modern and prehistoric skeletons of the Grey Seal *Halichoerus grypus*, the Ringed Seal *Phoca hispida*, the Harbour Seal *Phoca vitulina*, and the Harp Seal *Phoca groenlandica*. Although standard measuring methods for mammal skeletons exist (e.g., Duerst 1926, von den Driesch 1975) these are not particularly useful for measuring pinnipeds. This is mainly due to the many anatomical specializations in the pinniped postcranial skeleton in response to their aquatic locomotory adaptations.

The objective of the present manual is to encourage osteometric documentation of skeletal elements of seals and to increase comparability of studies. Measurements have been defined for the postcranial elements, the mandible and the temporal bone. No other measurements for the cranium are provided since these measurements can readily be transformed from standard works on mammalian osteology.

The measurement descriptions follow generally accepted definitions for skeletal elements of other mammals. The terminology of Duerst (1926) and von den Driesch (1976) is adhered to when possible, and the measurement abbreviation of von den Driesch is also given when the measurement descriptions are considered identical.

In archaeological bone samples the skeletal elements are often very fragmented as a result of numerous taphonomical factors, not least butchering and cooking practices by prehistoric Man. Few bones thus can be measured in full which calls for descriptions of measurements from diaphyses and other commonly found parts. Therefore some measurements described herein might be redundant if the complete element is available, as in studies of modern seal skeletons. In archaeological studies they make more sense however.

As in other aquatic mammals the skeletal growth is slow in seals with epiphyseals fusing to the bones late in life. Archaeozoological seal material are thus often dominated by unfused elements. This manual presents descriptions of how length measurements can be taken also on bones with both ends unfused. Lengths for elements with only one of the epiphyses fused can be derived from the other descriptions. In Table 1 the relative order of epiphyseal fusion in each skeletal element is presented.

*Table 1.* Relative order of epiphyseal fusion within selected skeletal elements of the genera *Phoca* and *Halichoerus*.

Skeletal element	Proximal end	Distal end
<b>Humerus</b>	<b>Last</b>	<b>First</b>
Radius	First	Last
Ulna	First (crista olecranon)	Last
Femur	First	Last
Os cruris (tibia and fibula)	First	Last
Metacarpus I / Metatarsus I	Last	First
Metacarpi II-V / Metatarsi II-V	First ( <i>in utero</i> )	Last
Phalanges 1 and 2 anterior	Last	First ( <i>in utero</i> )
Phalanges 1 and 2 posterior	Last	First

### General comments to the measurements:

The measurement differ in how easy they are to take. In the descriptions of the individual measurements below the level of difficulty, based on our own experiences, are indicated. With a + sign is meant that the measurement is rather easy to take, i.e. the bone is easy to orientate and the measuring points are well defined. A - sign indicates it is more difficult.

*Length* measurements for the axial skeleton (the scapula and innominate bone) are taken in a cranio-caudal direction. For the appendicular skeleton length measurements are proximo-distally directed.

*Breadth* is a medio-laterally directed measurement.

*Height* measurements for the axial skeleton are taken in the dorso-ventral dimension.

*Depth* is a cranio-caudally (i.e. dorso-volarly or dorso-plantarly) directed measurement (only taken in the appendicular skeleton).

*Diagonals* or *diameters* are terms for measurements taken in a direction other than those described above.

As this manual was also designed to facilitate zooarchaeological studies the empirically observed frequencies of individual measurements in faunal refuse samples are given. Our observations are based mainly on studies of bone assemblages from the Stone Age in the Baltic region. The codes are (following von den Driesch (1976)):

- 0 almost never possible to measure in archaeological material
- X rarely measurable
- XX rather commonly measurable
- XXX very commonly measurable

The illustrations below are based on elements of a Harbour Seal *Phoca vitulina*. Only for the temporal bone another species (the Harp Seal *Phoca groenlandica*) has been used. In the case of paired bones, the left side have been depicted if not stated otherwise. Please note that some skeletal elements exhibit a significant morphological variation between species and among individuals.

## References

Driesch, A. von den 1976. A guide to the measurement of animal bones from archaeological sites. *Peabody Museum Bulletin, 1*. Harvard University.

Duerst, J.U. 1926. Vergleichende Untersuchungsmethoden am Skelett bei Säugern. *Handbuch der biologischen Arbeitsmethoden, Abt. 7: Methoden der vergleichenden morphologischen Forschung, Heft 2*. Berlin & Wien.

## Os temporale

1. Greatest) diagonal length measured from the apex bullae to margin of pars mastoideus. (-) XXX
2. (Greatest) diagonal breadth of pars mastoideus. (+) XXX
3. Breadth measured from medial margin of bulla tympanicum to meatus acusticus externus.(-) XXX
4. Diagonal length of bulla tympanicum. (-) XXX
5. Diagonal breadth from the border of bulla tympanicum to meatus acusticus externus. (-) XXX

## Mandibula

1. Greatest length: processus condylus to *Infradentale*. (+) X
2. Length: processus condylus to the aboral border of the canine alveolus. (+) X
3. Length: processus angularis to *Infradentale*. (+) X
4. Length: processus angularis to the aboral border of the canine alveolus. (+) X
5. Length: oral border of foramen mentale to *Infradentale*. (+) X
6. Length: the most aboral point of the M<sub>1</sub> alveolus to the most aboral point of the canine alveolus. (+) XX
7. Length: the most aboral point of the M<sub>1</sub> alveolus to the most oral point of the P<sub>1</sub> alveolus. (+) XX
8. Height of ramus: processus angularis (point) to *Coronion* (Cr). (-) X
9. Minimum height of mandible behind M<sub>1</sub>. Measured on the lingual side at right angles to the basal border. (+) XXX
10. Height of mandible between P<sub>2</sub> and P<sub>3</sub>. Measured on the lingual side at right angles to the basal border. (+) XXX
11. Greatest thickness of mandible at P<sub>3</sub>. Not illustrated. (+) XXX
12. Breadth of processus condylus. (+) XX
13. Length of canine, crown to root, not illustrated. (+) XXX

- A Os temporale, basal view
- B Os temporale, basal view
- C Os temporale, basal view
- D Mandibula, medial view
- E Mandibula, caudal view

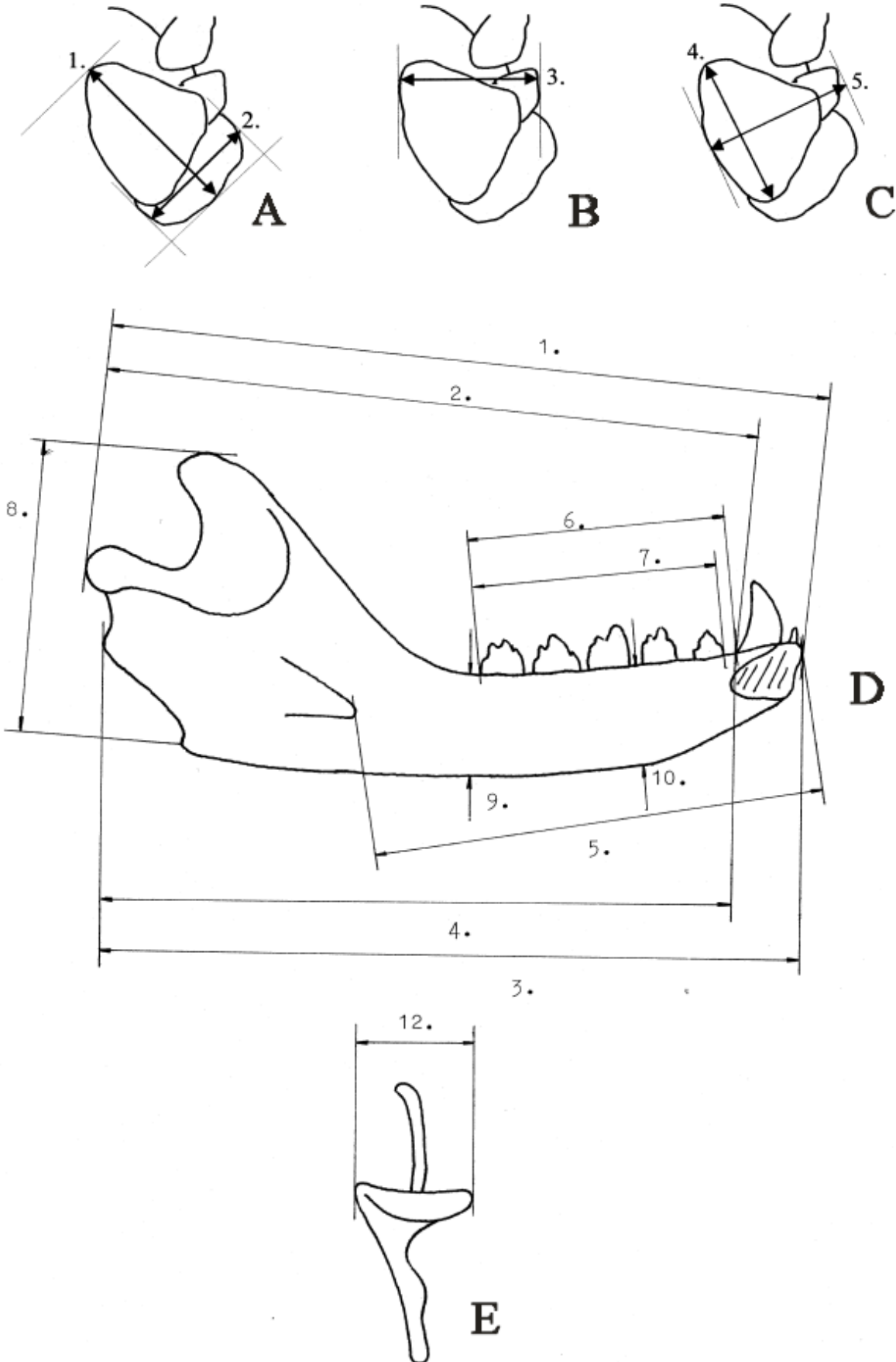

## Scapula

1. Diagonal height, DHA. (+, difficult to measure if the scapular cartilage has ossified) 0
2. Diagonal length from the cranial margin of processus articularis to the proximal point of angulus cervicalis. (-, *Phoca vitulina* +) X
3. Smallest length of collum scapulae, SLC. (+) XXX
4. Greatest length of processus articularis, GLP. (+) XX
5. Length of the glenoid cavity, measured in parallel to measurement 4. Including the cranial lip of the glenoid cavity, LG. (+/-) XX
6. Breadth of the glenoid cavity, BP. (+) XXX
7. Smallest breadth of collum scapulae. (+) XXX

- A Scapula, lateral view
- B Scapula, distal view
- C Scapula, caudal view



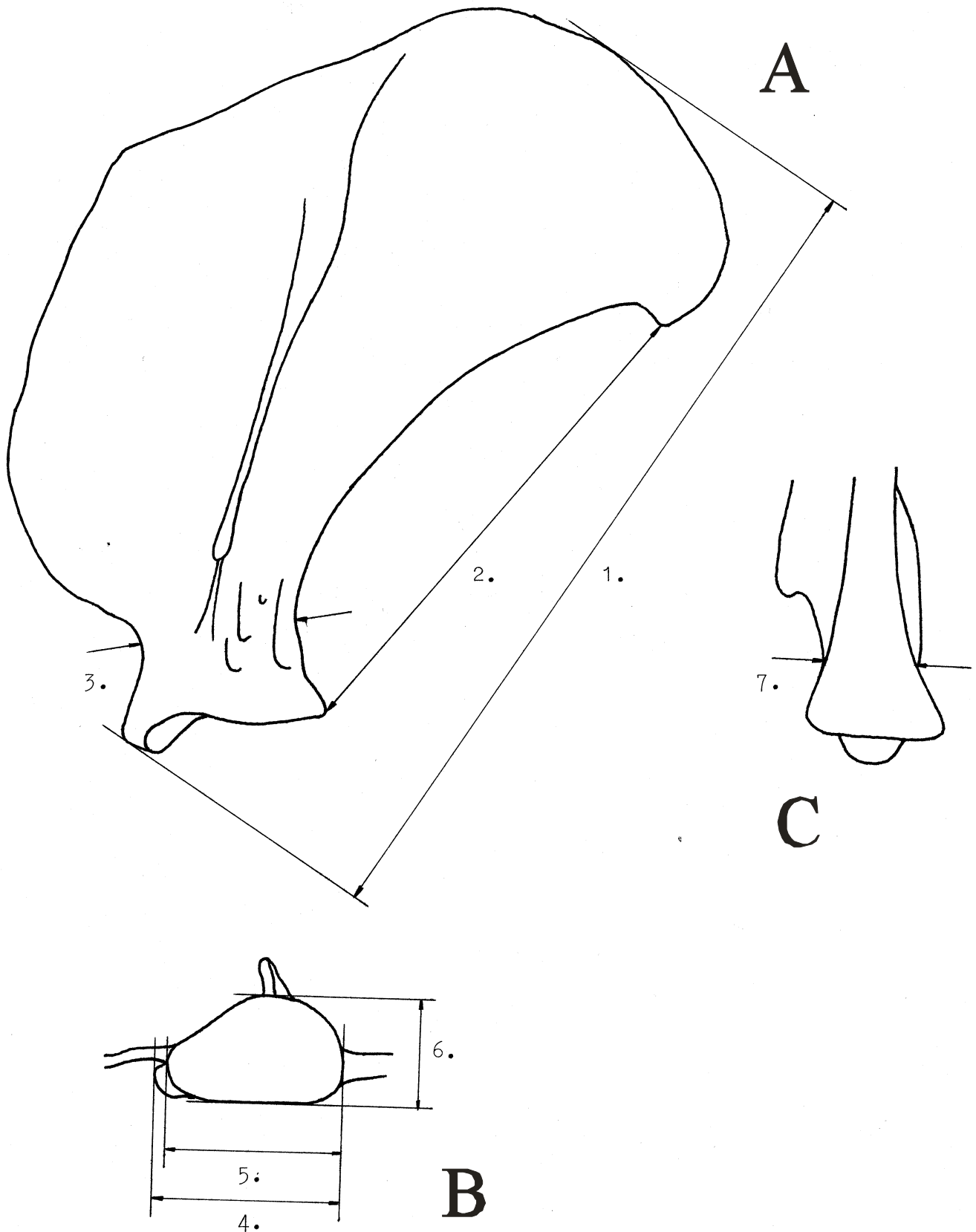

**Humerus**

1. Greatest length, GL. (+) XX
2. (Greatest) length with the condyles in one plane (in *Phoca groenlandica* often identical with measurement 3). (+) XX
3. Greatest length from caput, GLC. (+) XX
4. Depth of the proximal end, Dp. (+) XX
5. Greatest transversal diameter of caput. (+, *Halichoerus* -) XX
6. Smallest diagonal breadth of diaphysis. (-) XXX
7. Smallest height of diaphysis. (+) XXX
8. (Greatest) breadth of distal end, Bd. (-) XX
9. (Greatest) breadth of trochlea, with condyles in one plane, BT. (-) XXX
10. Greatest diagonal height of condylus lateralis. (+, *Halichoerus* and *Phoca vitulina* -) XXX

- A Humerus, caudal view – diaphysis with unfused epiphyses
- B Humerus, caudo-lateral view
- C Humerus, cross-section of diaphysis
  
- D Humerus, cross-section of diaphysis
- E Humerus, caudal view
- F Humerus, lateral view
  
- G Humerus, cranial view
- H Humerus, medial view

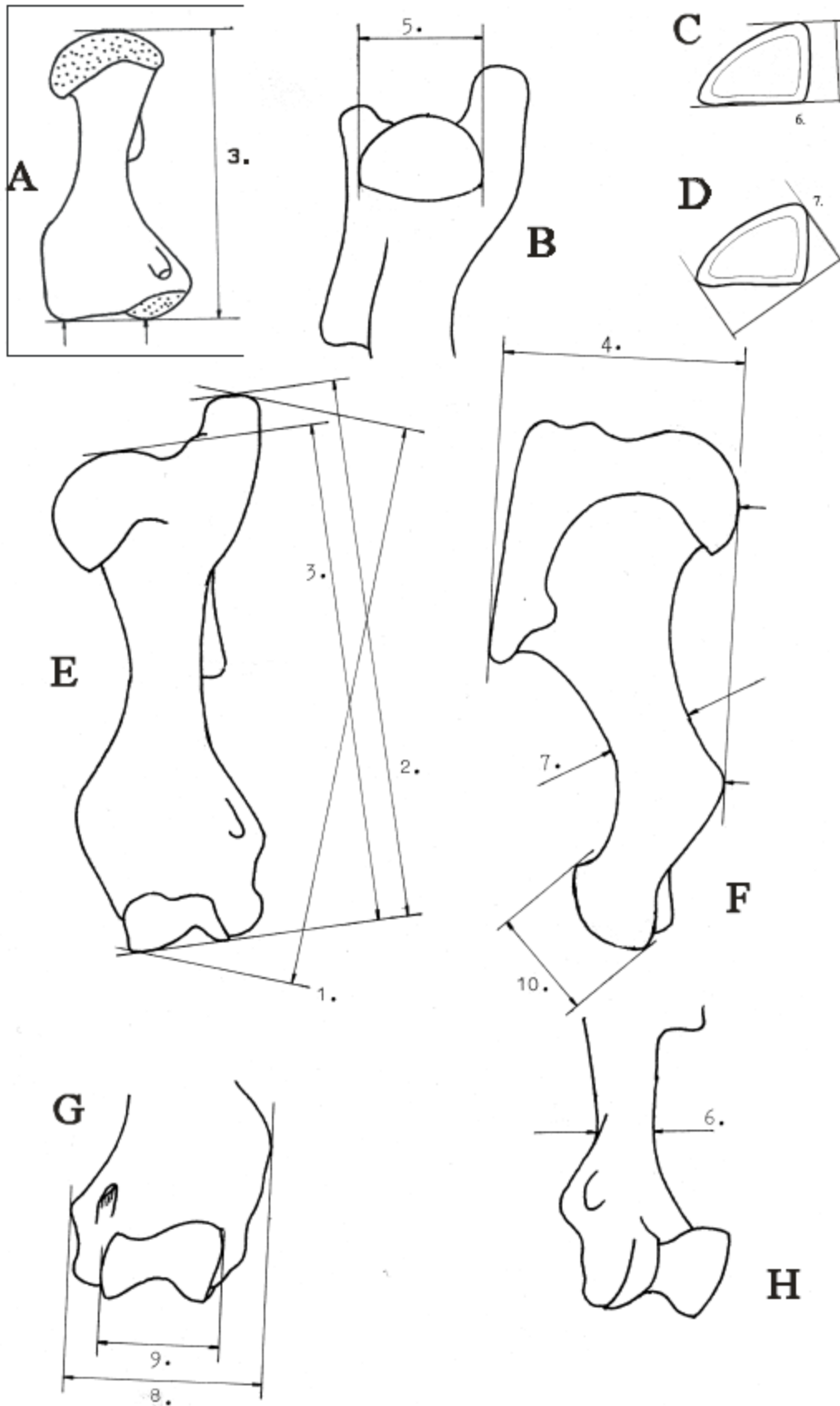

## Radius

1. Greatest length, GL. (+) XX
2. Length measured with the medial and lateral borders of the distal articular surfaces in one plane. (+) XX
3. (Greatest) depth of the head. (+) XXX
4. (Greatest) diagonal breadth of the head. (+) XXX
5. (Smallest) diagonal depth of the diaphysis measured distal of the attachment of the tuberositas radii. (+) XXX
6. (Greatest) diagonal depth of the diaphysis. (+) X
7. (Smallest) breadth of the diaphysis. (+) XXX
8. (Greatest) depth of the distal articular surface. (-) XX
9. (Greatest) breadth of the distal articular surface. (-) XX

A Radius, proximal view

B Radius, dorsal view

C Radius, lateral view

D Radius, dorsal view – diaphysis with unfused epiphyses

E Radius, distal view

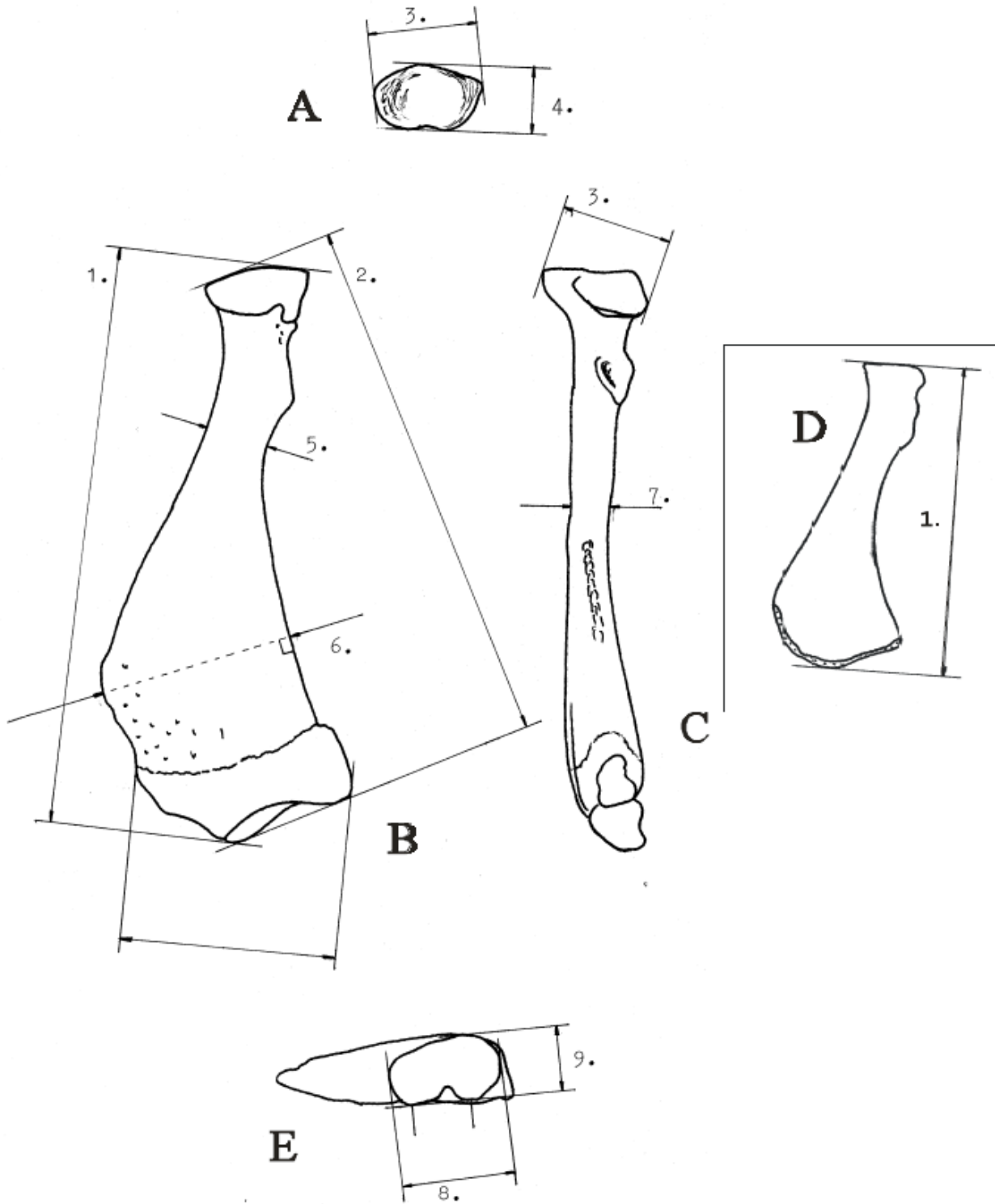

## Ulna

1. Greatest length, GL. (+) X
2. Greatest depth of the cranial border of olecranon. (+) XX
3. Smallest depth of the olecranon, SDO. (+) XX
4. (Smallest) depth: processus anconaeus to the caudal border of the ulna, DPA. (+) XX
5. (Greatest) breadth of the proximal articular surface. (+) XXX
6. (Greatest) diagonal length of proximal articular surface. (+) XXX
7. (Smallest) depth of the diaphysis. (+) XXX
8. (Smallest) breadth of the lower part of the diaphysis. (+) XXX

- A Ulna, volar view  
B Ulna, medial view  
C Ulna, volar view – diaphysis with unfused epiphyses

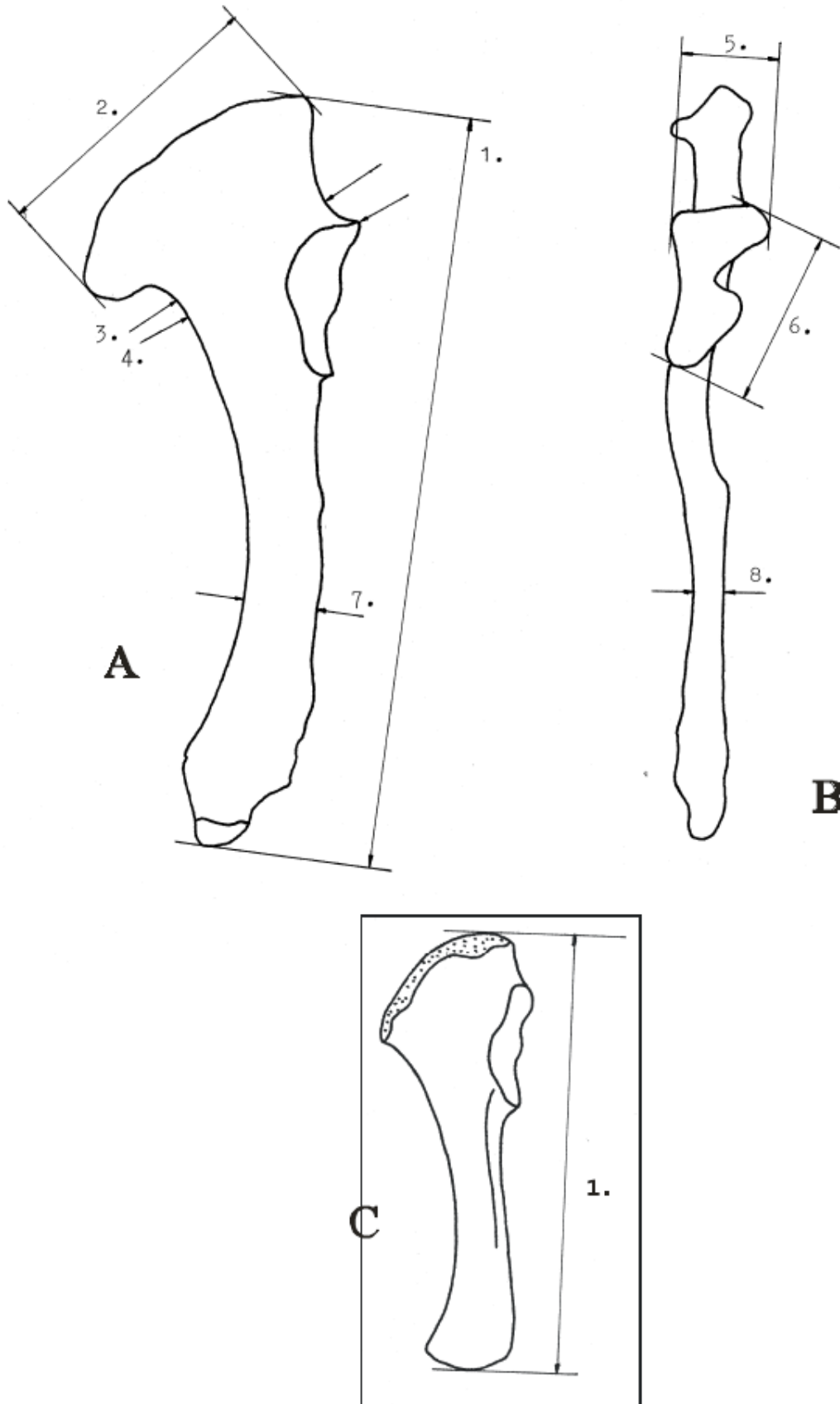

**Os coxae**

1. Greatest length: greatest diagonal length, GL. (+) 0
2. Greatest breadth of crista ilium. (+, *Halichoerus* -) 0
3. (Smallest) breadth of os ilium. (-) XX
4. Breadth cross centrum of acetabulum. (-) XXX
5. Length of acetabulum (on the rim) LAR. (-) XXX
- 5b. Breadth of acetabulum (on the rim). (-) XXX
6. (Smallest) length between the caudal border of the acetabulum and the cranial border of the foramen obturatum. (-) XXX
7. Inner length of the foramen obturatum, Lfo. (+) 0
8. Inner breadth of the foramen obturatum. (+) 0
9. Breadth: tuber ischiadicum to the medial border of os pubis. (+) 0
10. Breadth: tuber ischiadicum to the medial border of os ischium. (+) 0
11. (Smallest) diagonal breadth of os ischium measured caudal of tuber ischiadicum. (+) 0

**Os baculum**

1. Greatest length, not illustrated. (+) 0

- A Os coxae, lateral view  
B Os coxae, cranial view



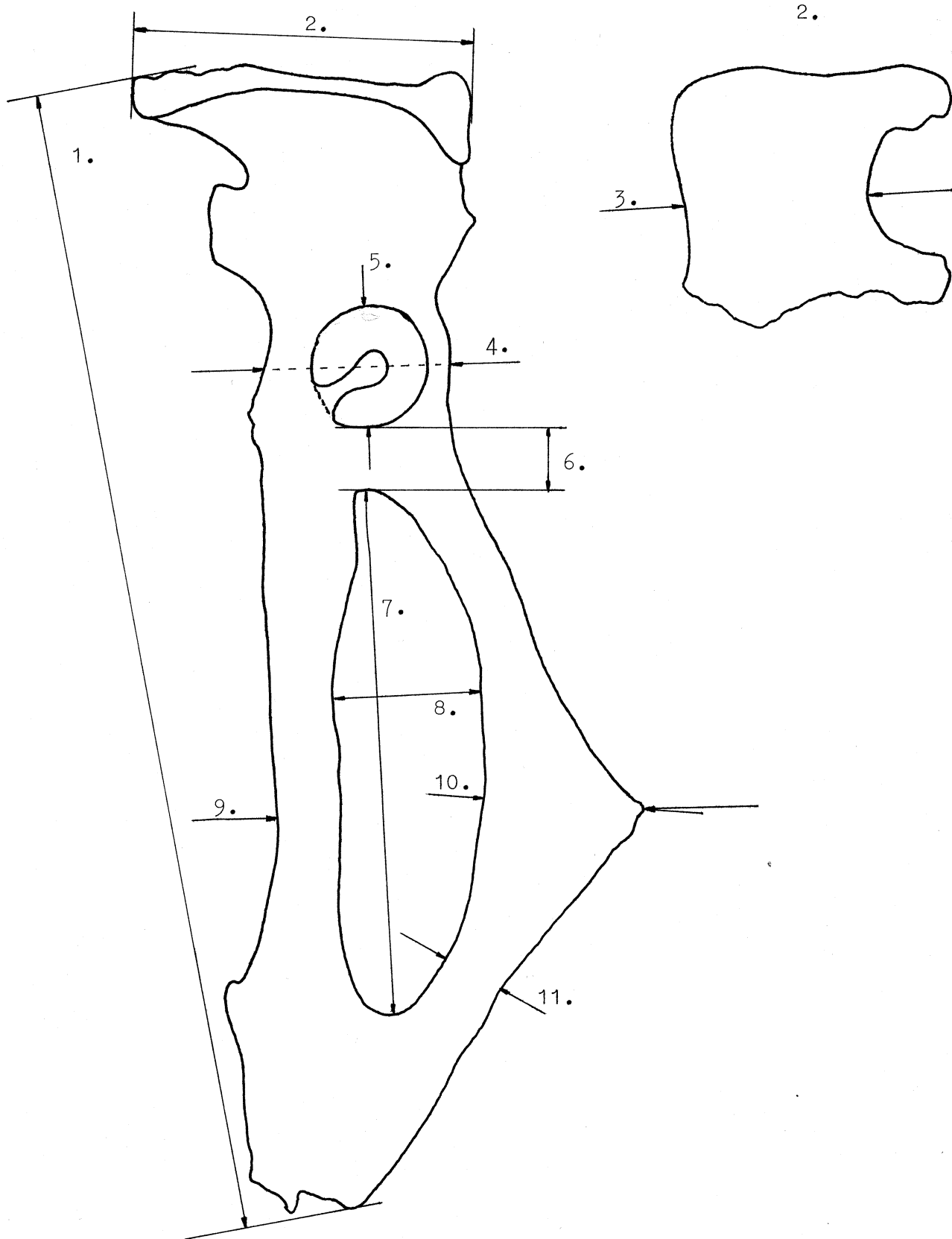

## **Femur**

1. Greatest length, GL. (+) XX
2. Length measured with the distal condyles in one plane. (+) XX
3. (Greatest) breadth of the proximal end, Bp. (+) XXX
4. (Greatest) diagonal breadth of the major trochanter. (-) XXX
5. (Greatest) depth of the head, DC. (+) XX
6. (Smallest) breadth of diaphysis, SD. (+) XXX
7. (Greatest) depth of diaphysis at measurement 6. (+) XXX
8. (Greatest) breadth of the distal condyles. (+) XX
9. (Smallest) length of corpus. (+) XXX

- A Femur, cranial view
- B Femur, medial view
- C Femur, distal view
- D Femur, cranial view – diaphysis with unfused epiphyses

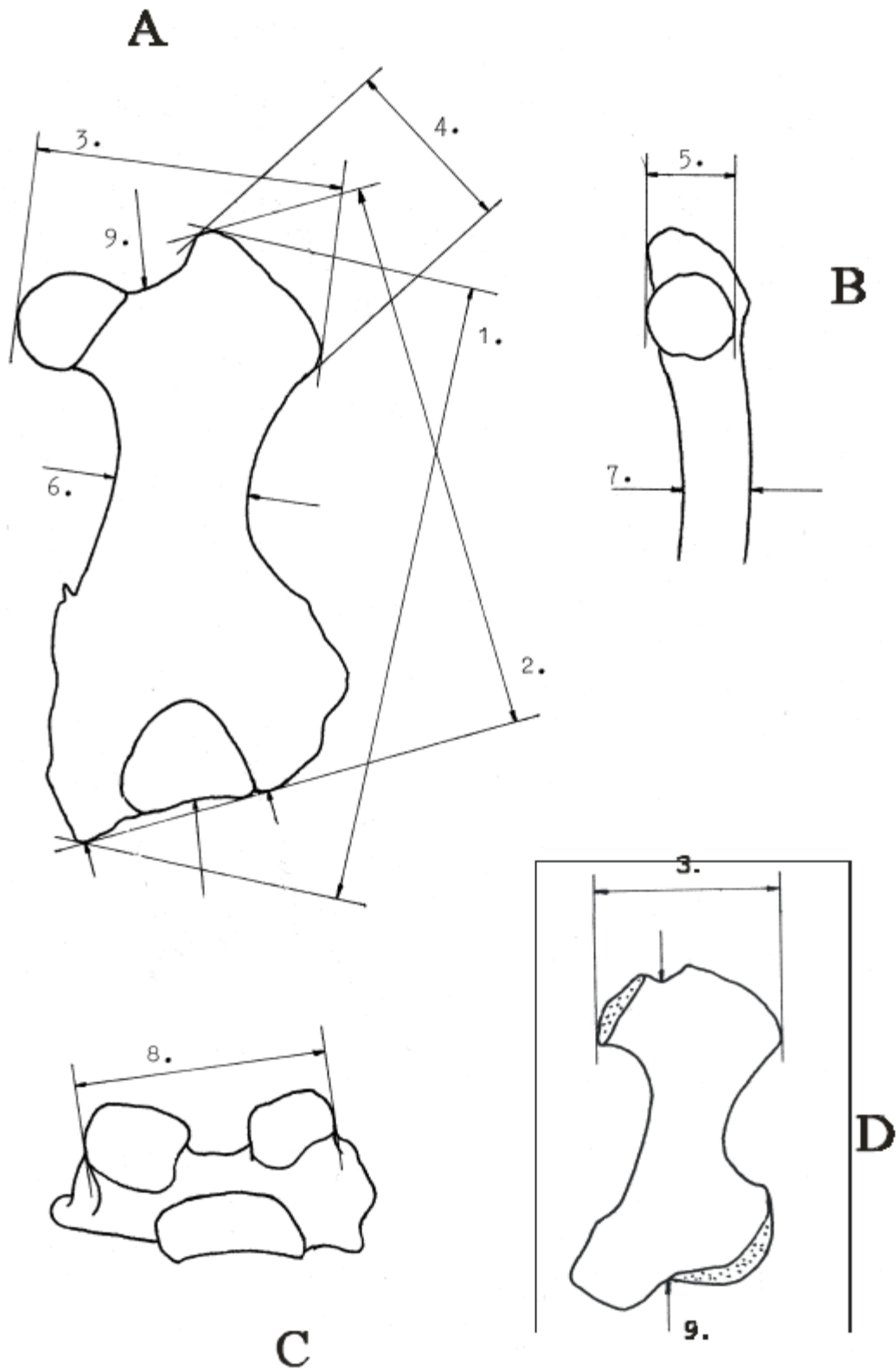

### **Os cruris - tibia and fibula**

1. (Greatest) breadth of the proximal articular surfaces. (-) XX
2. (Smallest) depth measured between the proximal articular surfaces. (+) XX
3. Greatest length, GL. (+) 0
4. (Greatest) breadth of the distal tibial end at the fusion between the diaphysis and epiphysis.  
(+) XX
5. (Greatest) breadth of the distal fibular end at the fusion between the diaphysis and epiphysis.  
(+) X
6. (Greatest) depth of the distal fibular end at the fusion between the diaphysis and epiphysis.  
(+) X

NOTE: These bones are all from right side.

- A Os cruris, proximal view
- B Os cruris, plantar view
- C Tibia, distal view
  
- D Fibula, distal view
- E Tibia, plantar view – diaphysis with unfused epiphyses
- F Fibula, plantar view – diaphysis with unfused epiphyses

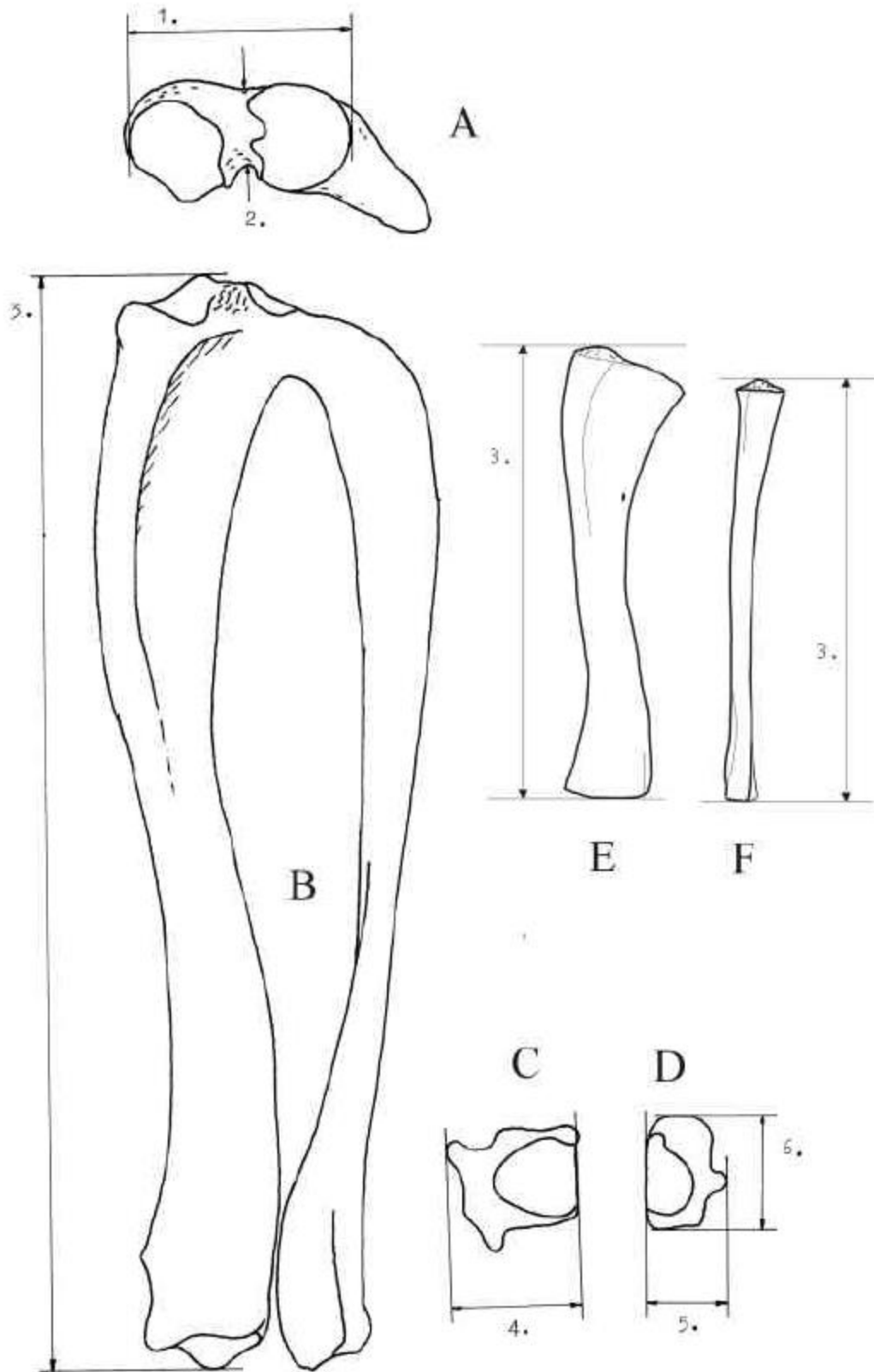

### **Astragalus**

1. Greatest length, GL. (+) XX
2. (Greatest) length from the most proximal point of the trochlea to the most distal point of the astragalus. (+) XX
3. (Greatest) breadth of the trochlea. (+) XX
4. (Greatest) height. (+) XX

### **Calcaneus**

1. Greatest length: greatest diagonal length. (+) X
2. Greatest height. (+) X

- A Astragalus, proximal view
- B Astragalus, lateral view
- C Calcaneus, medial view

A

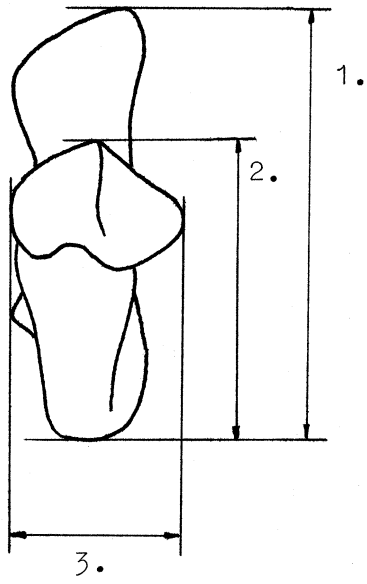

B

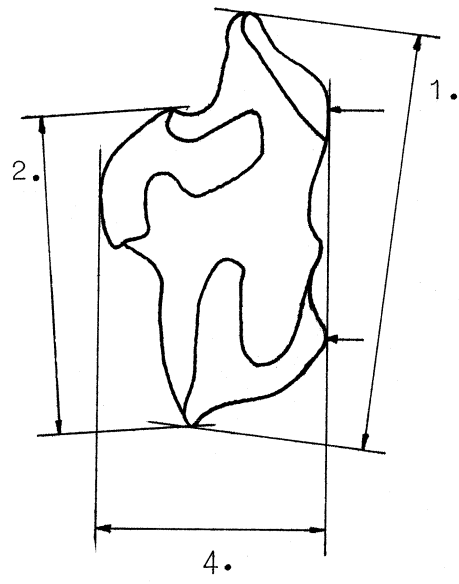

C

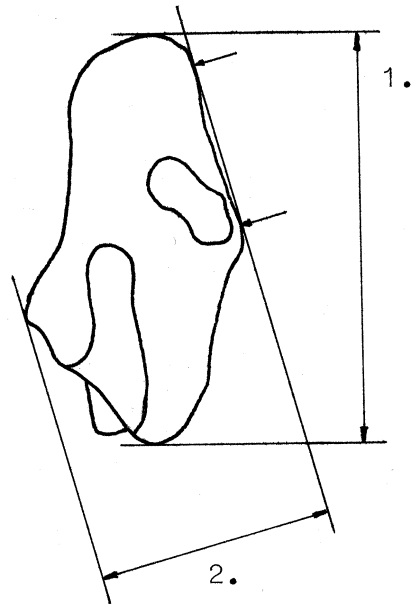

**Metacarpalia and metatarsalia (only Mc IV and Mt I illustrated)**

1. Greatest length. (+) XXX
2. (Greatest) breadth of proximal end. (-) XXX
3. (Smallest) breadth of diaphysis. (+) XXX
4. (Greatest) breadth of distal end. (-) XXX
5. (Greatest) height of proximal end of metatarsal I. (+) XXX

**Phalanges (phalanx 3 not illustrated)**

1. Greatest length. (+ , phalanx 3 -) XXX
2. (Greatest) breadth of proximal end. (+) XXX
3. (Smallest) breadth of diaphysis (not taken on phalanx 3). (+ , phalanx 1 anterior -) XXX
4. (Greatest) breadth of distal end (not taken on phalanx 3). (-) XXX

- A Metacarpus IV, distal view, right side  
 B Phalanges 1 anterior, distal view, right side  
 C Phalanges 2 anterior, distal view
- D Metacarpus IV, dorsal view, right side  
 E Phalanges 1 anterior, dorsal view, right side  
 F Phalanges 2 anterior, dorsal view
- G Metacarpus IV, proximal view, right side  
 H Phalanges 1 anterior, proximal view, right side  
 I Phalanges 2 anterior, proximal view
- J Metatarsus 1 posterior, distal view  
 K Phalanges 1 posterior, distal view  
 L Phalanges 2 posterior, distal view
- M Metatarsus 1 posterior, dorsal view  
 N Phalanges 1 posterior, dorsal view  
 O Phalanges 2 posterior, dorsal view
- P Metatarsus 1 posterior, proximal view  
 Q Phalanges 1 posterior, proximal view  
 R Phalanges 2 posterior, proximal view



